

In-Plane Conductivity Testing Procedures & Results

Work performed under subcontract with FSEC/UCF
DOE Award No. DE-FC36-06GO16028

Samples Tested:

N112

NRE212

NRE211

N117

N1035

N1135



This Presentation Covers the Following

- Testing Procedures Used for In-Plane Conductivity Tests
- Results from the five types of Nafion tested (N112, NRE212, NRE211, N117, N1035, N1135)
- Open Discussion Regarding Questions and/or Concerns Related to the Procedures, Assumptions, etc.



Example of Data Collected

Summary of Results at 120°C

Four Electrode Conductivities of Nafion at 120C

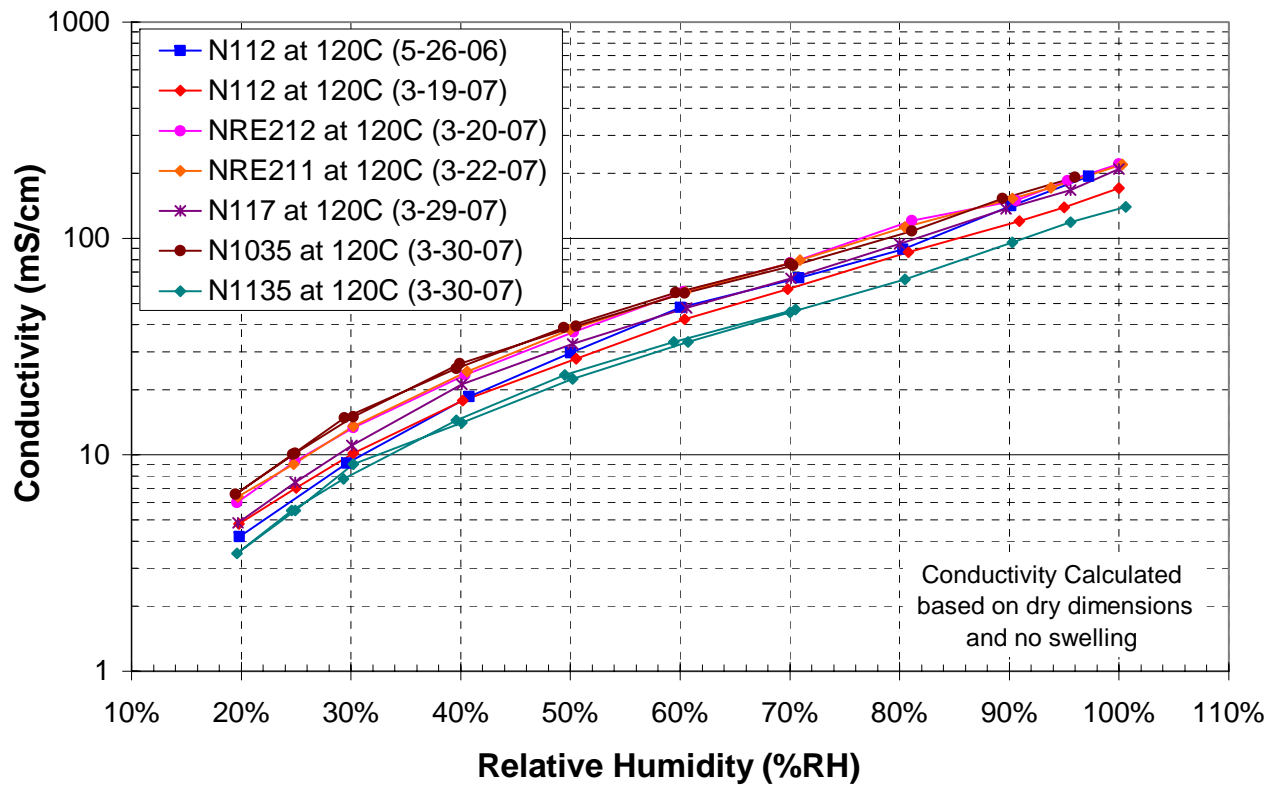

Testing Procedures

Sample Preparation

- Sample was cut to approximately 3mm x 20mm
- Sample assembled into the BekkTech Conductivity Cell
- BekkTech Conductivity Cell assembled into Fuel Cell Technologies fuel cell hardware
- Operating conditions controlled by the BT-512 BekkTech Membrane Conductivity Test System which includes a Keithley 2400 Sourcemeter for electrical measurements
- Cell temperature ramped to the operating temperature
- Sample was tested first at 30C, then 80C, then 120C



Membrane Assembly Technique

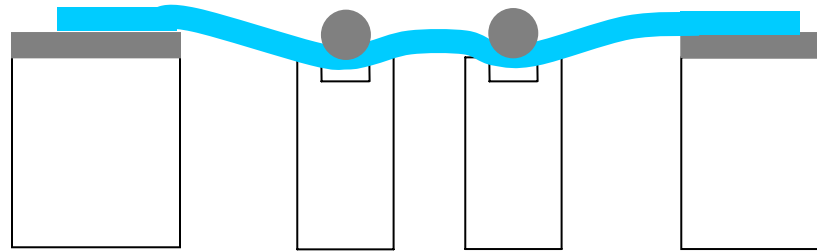

Placing membrane under platinum wires in the conductivity cell traps water and makes better contact with the membrane.

Thermocouple Placement

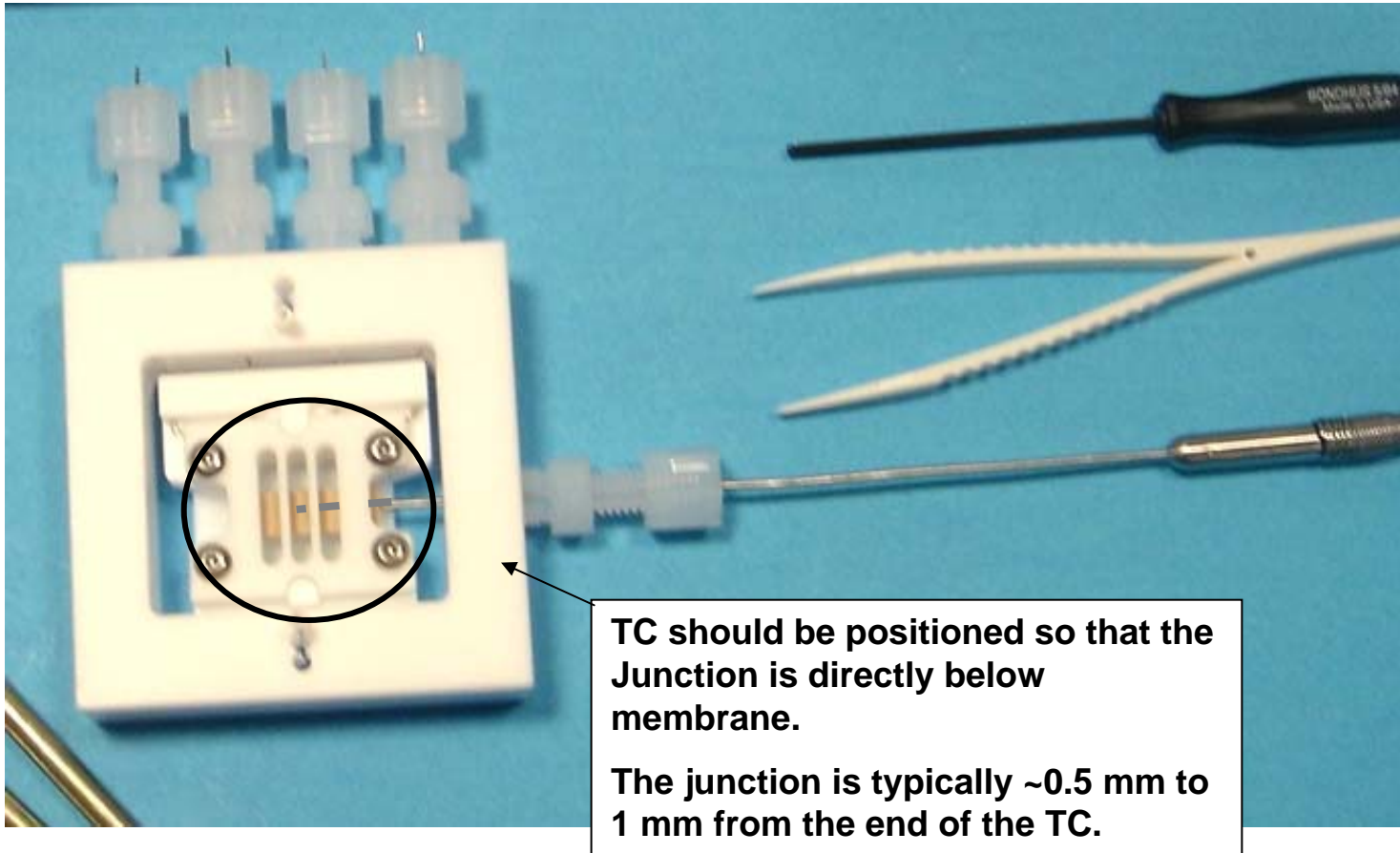

Conductivity Cell Assembly

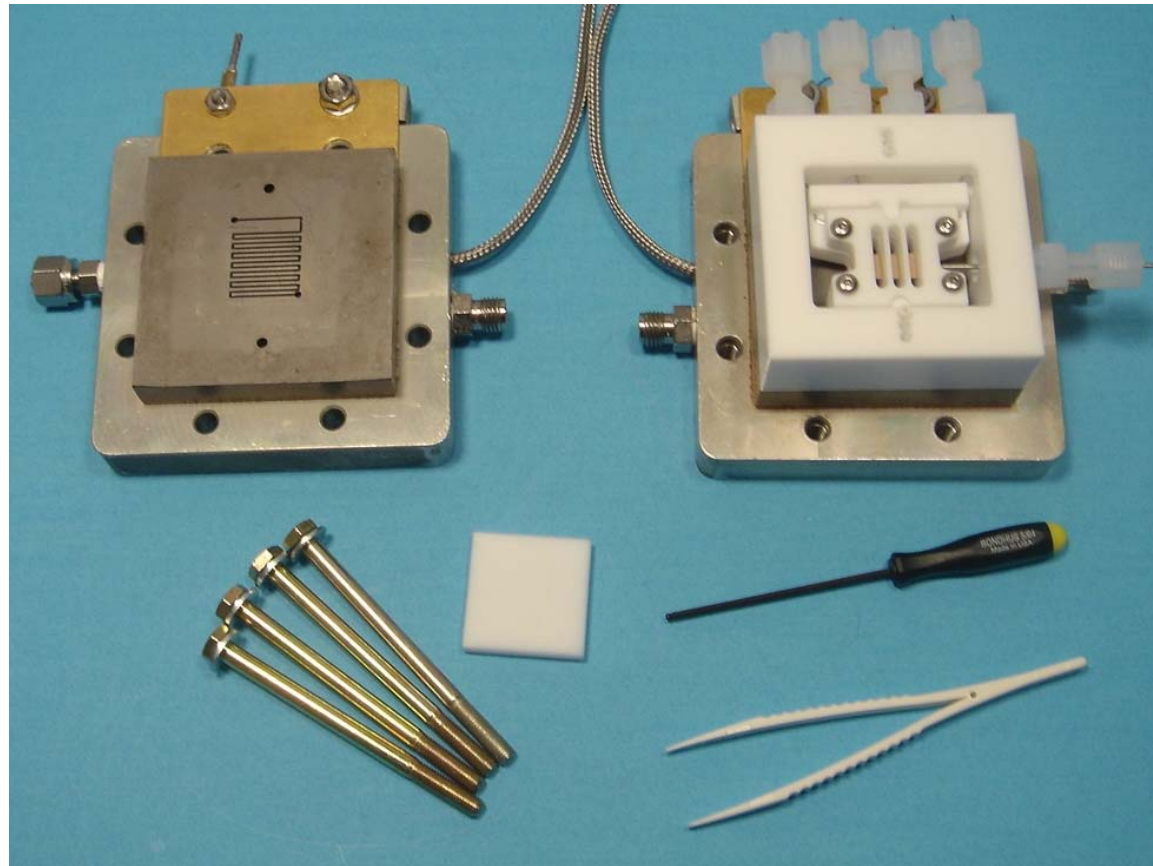

BT-512 Membrane Conductivity Test System

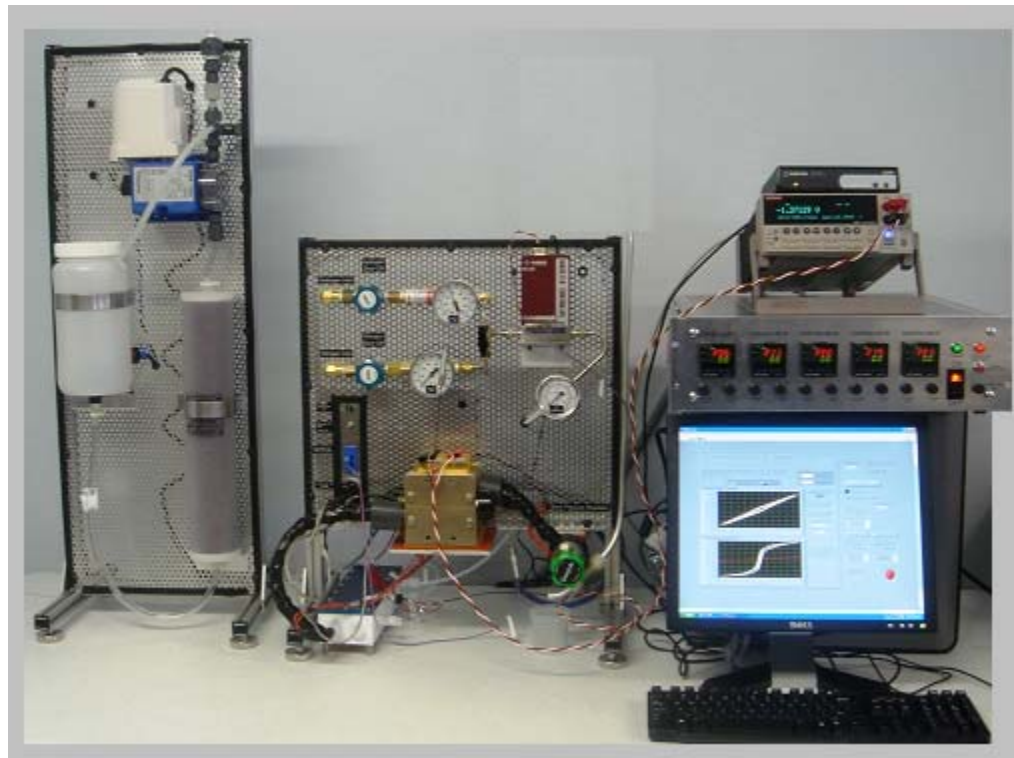

Shown with the BT-302 Pressurized DI Water System



Testing Conditions

Cell Pressure

- At 30C – 100kPa, ~15kPa gauge at BekkTech
- At 80C – 100kPa, ~15kPa gauge at BekkTech
- At 120C – 230kPa, ~145kPa gauge at BekkTech



Testing Conditions

Relative Humidity

- Hold for 2 hours at 70% RH
- Adjust RH as follows, holding for 15 minutes at each RH: 60%, 50%, 40%, 30%, 25%, 20%
- Adjust RH as follows, holding for 15 minutes at each RH: 25%, 30%, 40%, 50%, 60%, 70%, 80%, 90%, 95%, 100%



Testing Conditions

Electrical Measurement

- Voltage-Current values are set and measured using the Keithley 2400 SourceMeter.
- A scanning DC sweep is performed from +0.1 Volts to -0.1 Volts
- .01V (10mV) steps for ~1.8 seconds each step
- Resistance values are calculated using a least squares fit.
- Conductivity is calculated using the sample thickness, sample width, and distance between the platinum wires in the Conductivity Cell. (See Slide #27 for Calculation)



Gas Mixing to Achieve Desired RHs for 30C Tests

Relative Humidity (%RH)	Wet Gas Flow Rate (45 C dew point) (SCCM)	Dry Gas Flow Rate (-50 C dew point) (SCCM)
70%	289	711
60%	246	754
50%	204	796
40%	163	837
30%	122	878
25%	101	899
20%	81	919
25%	101	899
30%	122	878
40%	163	837
50%	204	796
60%	246	754
70%	289	711
80%	331	669
90%	396	604
100%	418	582



Saturator Settings for 80C Tests

- Dew Point of 44.8 C for 20% RH
- Dew Point of 49.2 C for 25% RH
- Dew Point of 52.9 C for 30% RH
- Dew Point of 58.9 C for 40% RH
- Dew Point of 63.8 C for 50% RH
- Dew Point of 67.9 C for 60% RH
- Dew Point of 71.4 C for 70% RH
- Dew Point of 74.6 C for 80% RH
- Dew Point of 77.4 C for 90% RH
- Dew Point of 78.7 C for 95% RH
- Dew Point of 80.0 C for 100% RH



Saturator Settings for 120C Tests

- Dew Point of 75.7 C for 20% RH
- Dew Point of 81.1 C for 25% RH
- Dew Point of 85.7 C for 30% RH
- Dew Point of 93.3 C for 40% RH
- Dew Point of 99.4 C for 50% RH
- Dew Point of 104.6 C for 60% RH
- Dew Point of 109.1 C for 70% RH
- Dew Point of 113.1 C for 80% RH
- Dew Point of 116.7 C for 90% RH
- Dew Point of 118.4 C for 95 % RH
- Dew Point of 120.0 C for 100% RH



Sample of the Data Collected on Each Sample

**Four Electrode Conductivity
120 C at 230 kPa**

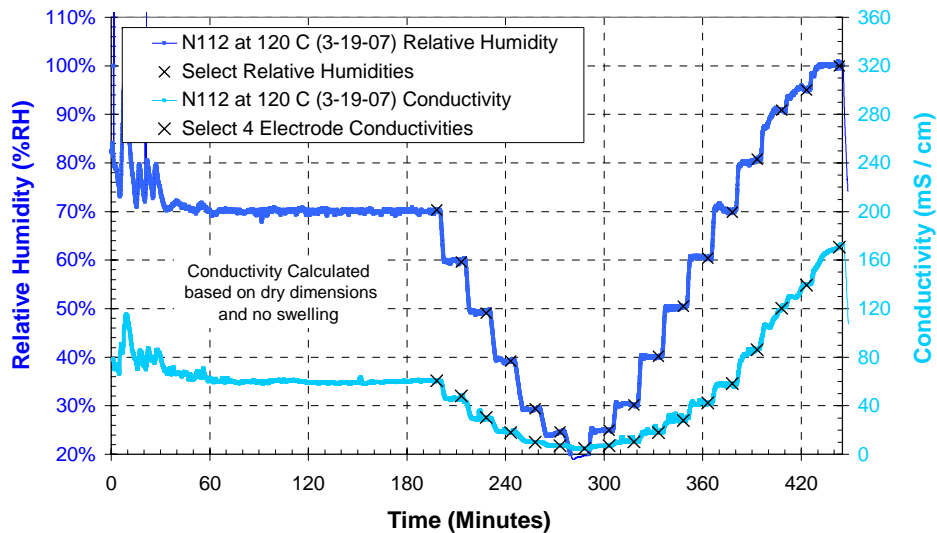

**Comparing Four Electrode Conductivity of N112
120 C 230 kPa**

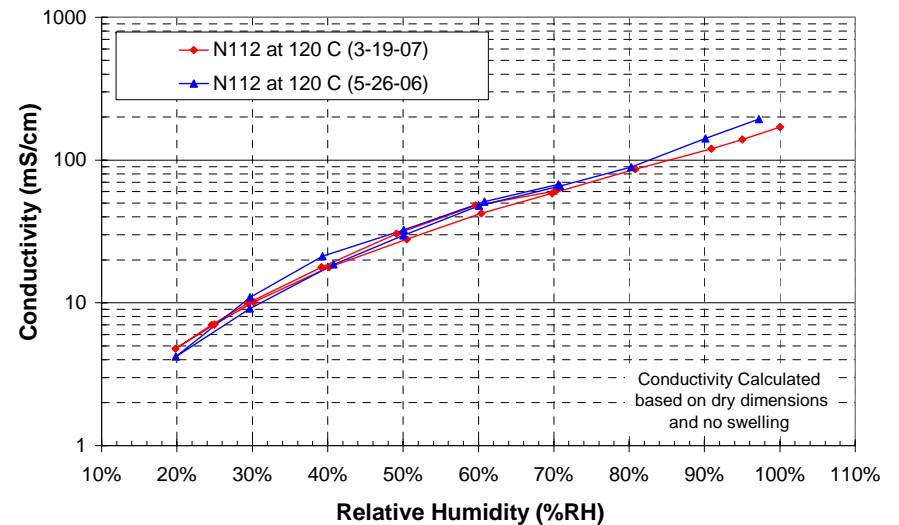

N112 at 120 C



Nafion Samples at 30 C

Summary of Results (Increasing RH Only)

Four Electrode Conductivities of Nafion at 30C

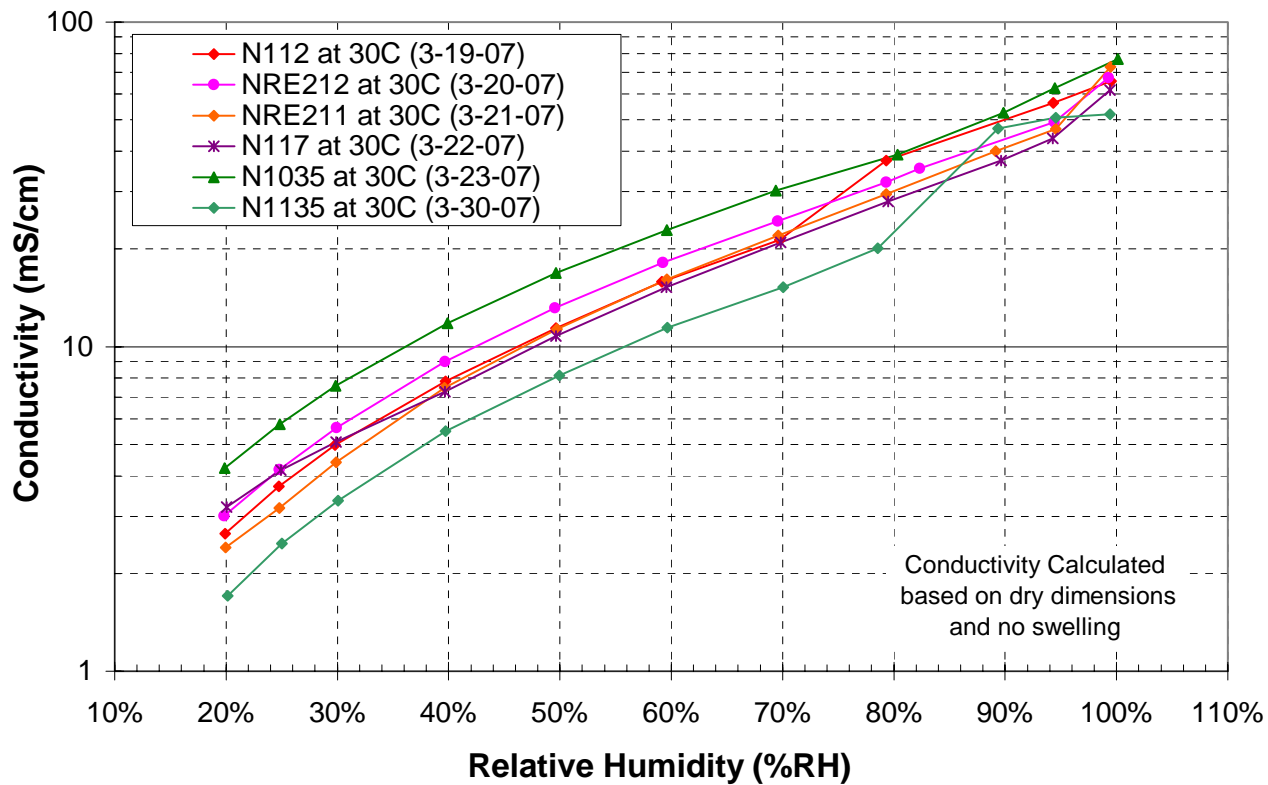

Nafion Samples at 80 C

Summary of Results (Increasing RH Only)

Four Electrode Conductivities of Nafion at 80C

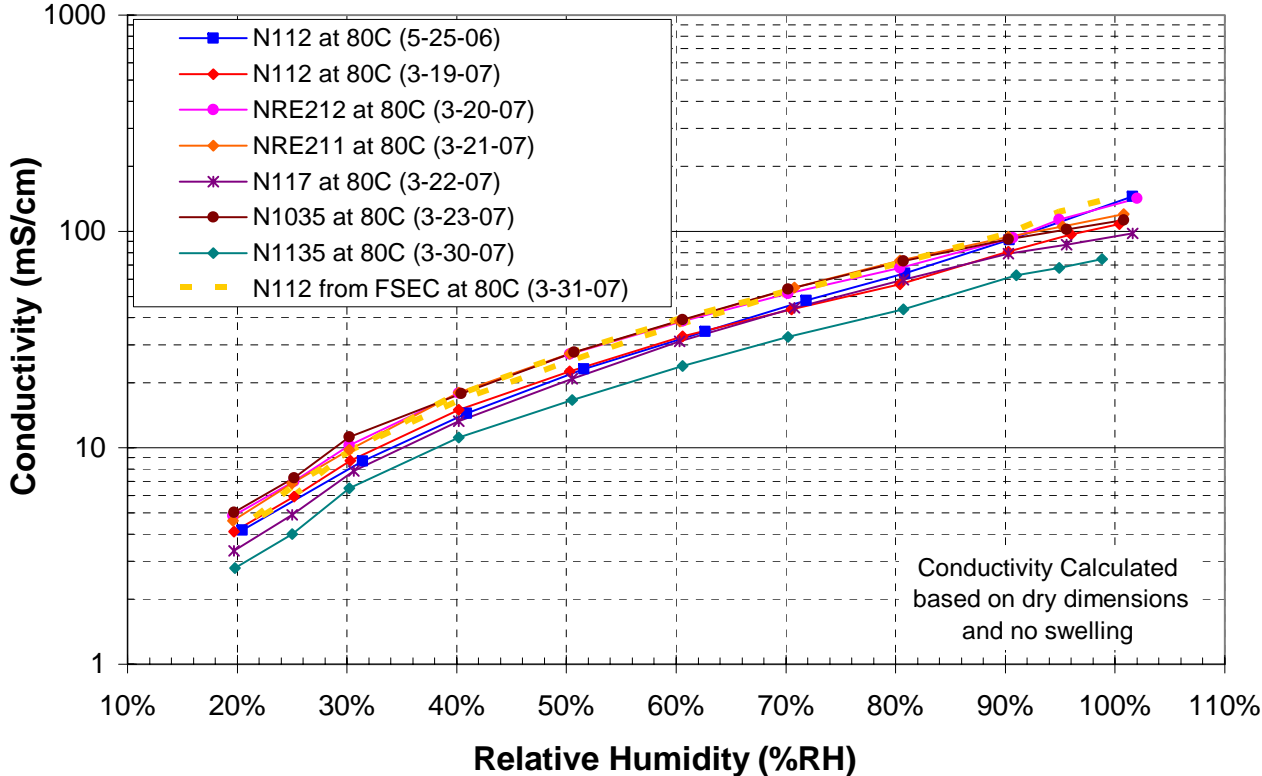

Nafion Samples at 120 C

Summary of Results (Increasing RH Only)

Four Electrode Conductivities of Nafion at 120C

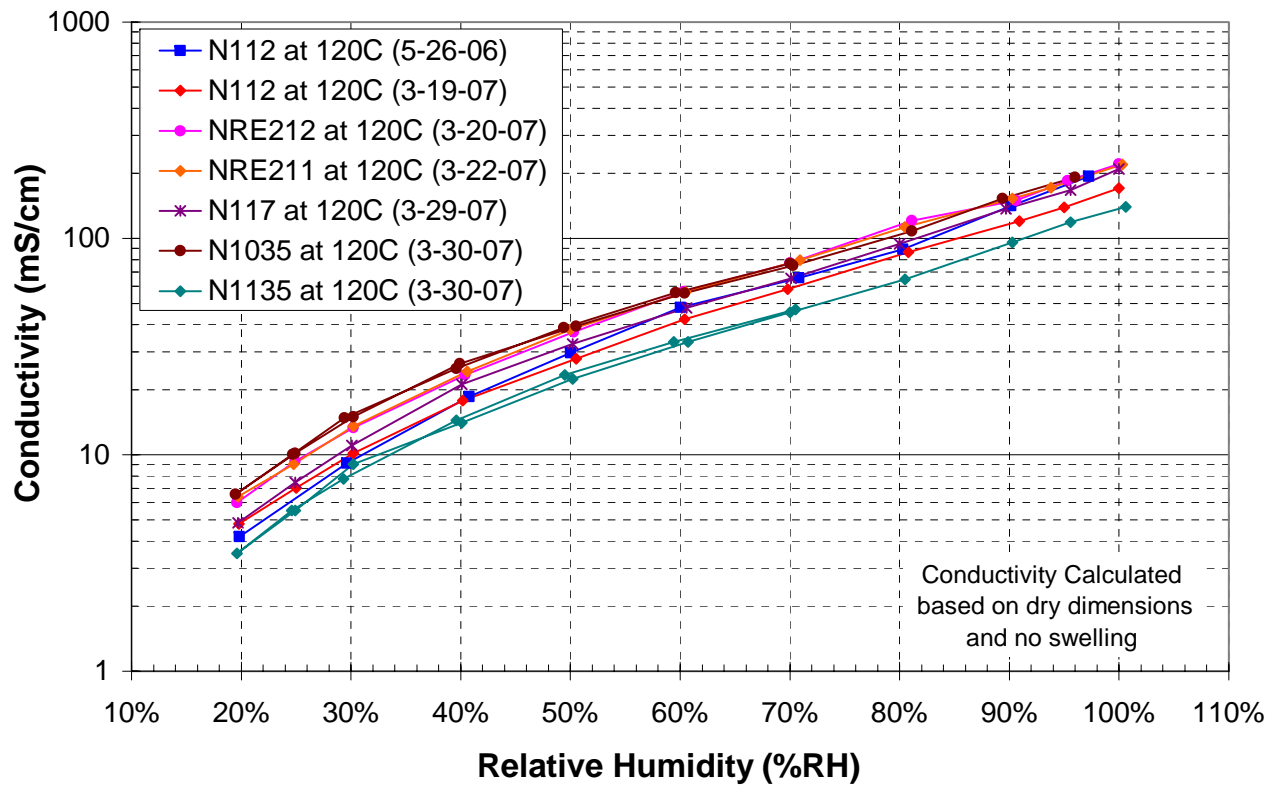

NRE212 at Each Temperature

Four Electrode Conductivities of NRE212

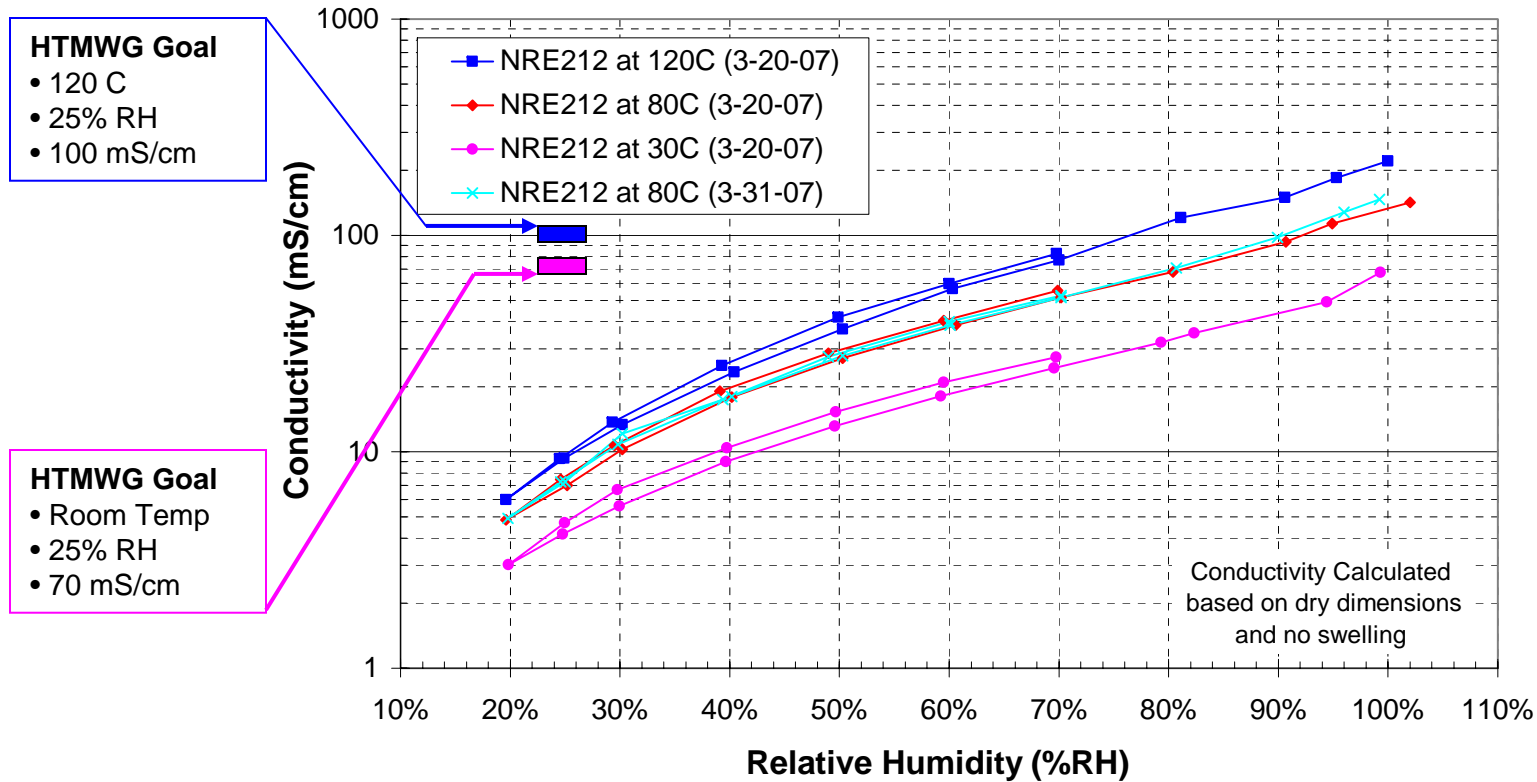

Next Steps

- Perform Gauge Studies (with FSEC and Scribner Associates) to document the repeatability & reproducibility of in-plane conductivity testing between labs
- Participate with FSEC in Sensitivity Analysis Studies (regarding length, width, thickness, and RH measurements)
- Develop procedures for reliable measurement of sample thickness. We are currently investigating tools and procedures.
- Begin testing samples developed by participants in this program.

Work performed under subcontract with FSEC/UCF
DOE Award No. DE-FC36-06GO16028



Questions ...

- Procedures
- Equipment
- Results
- Other

Additional Information

- Slide #22 N112 at Each Temperature
- Slide #23 NRE211 at Each Temperature
- Slide #24 N117 at Each Temperature
- Slide #25 N1035 at Each Temperature
- Slide #26 N1135 at Each Temperature
- Slide #27 Conductivity Calculation



N112 at Each Temperature

Four Electrode Conductivities N112

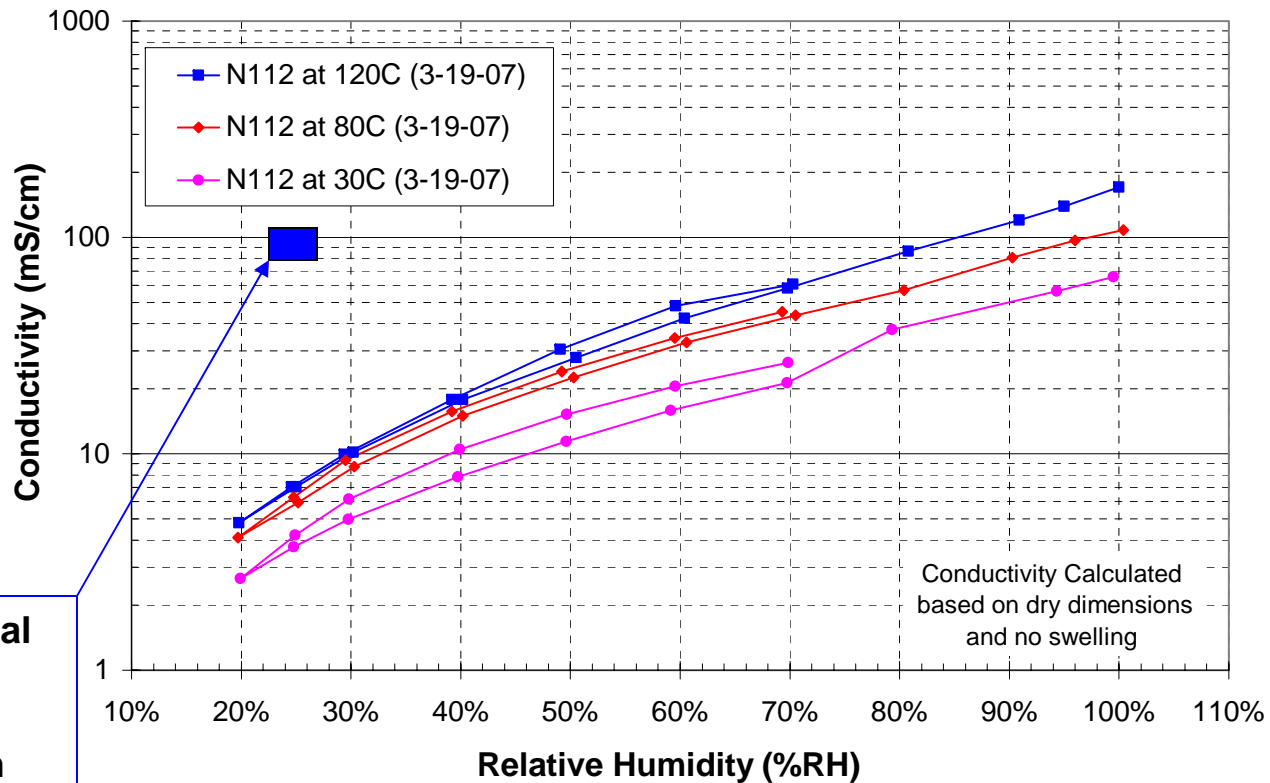

NRE211 at Each Temperature

Four Electrode Conductivities of NRE211

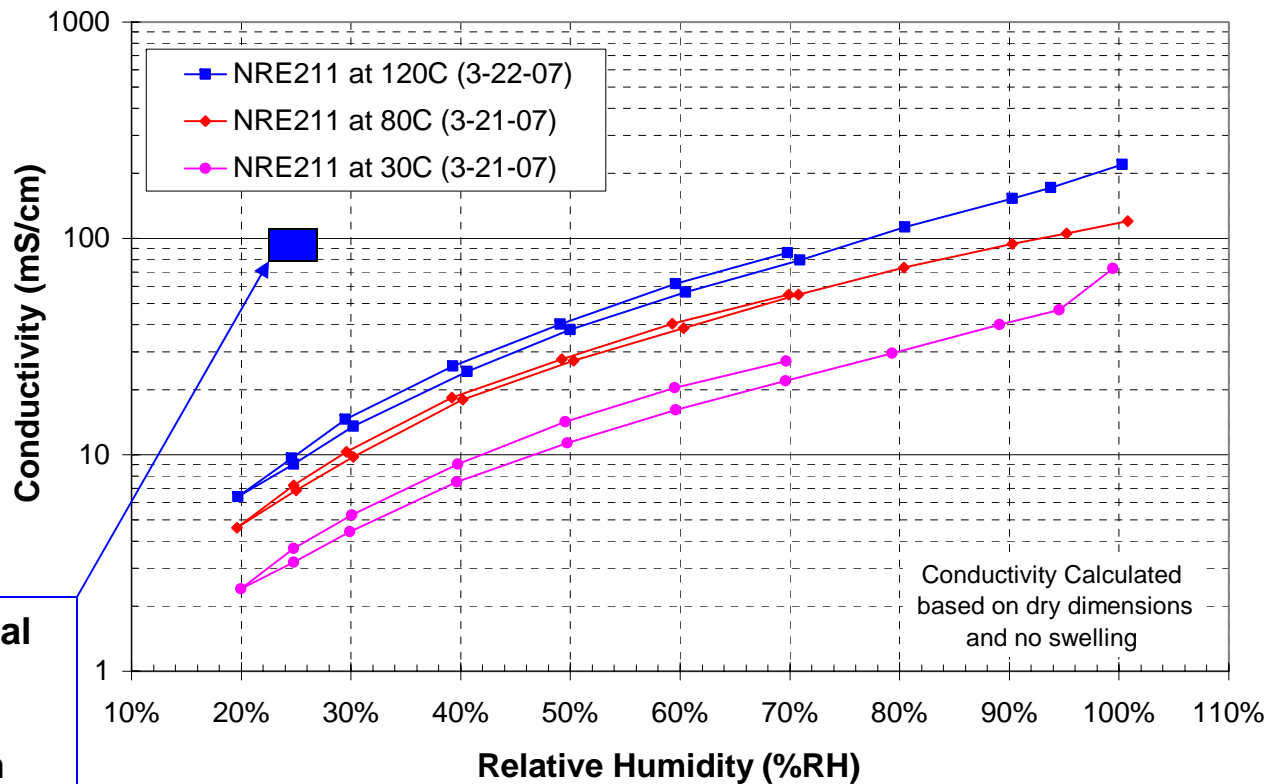

N117 at Each Temperature

Four Electrode Conductivities of N117

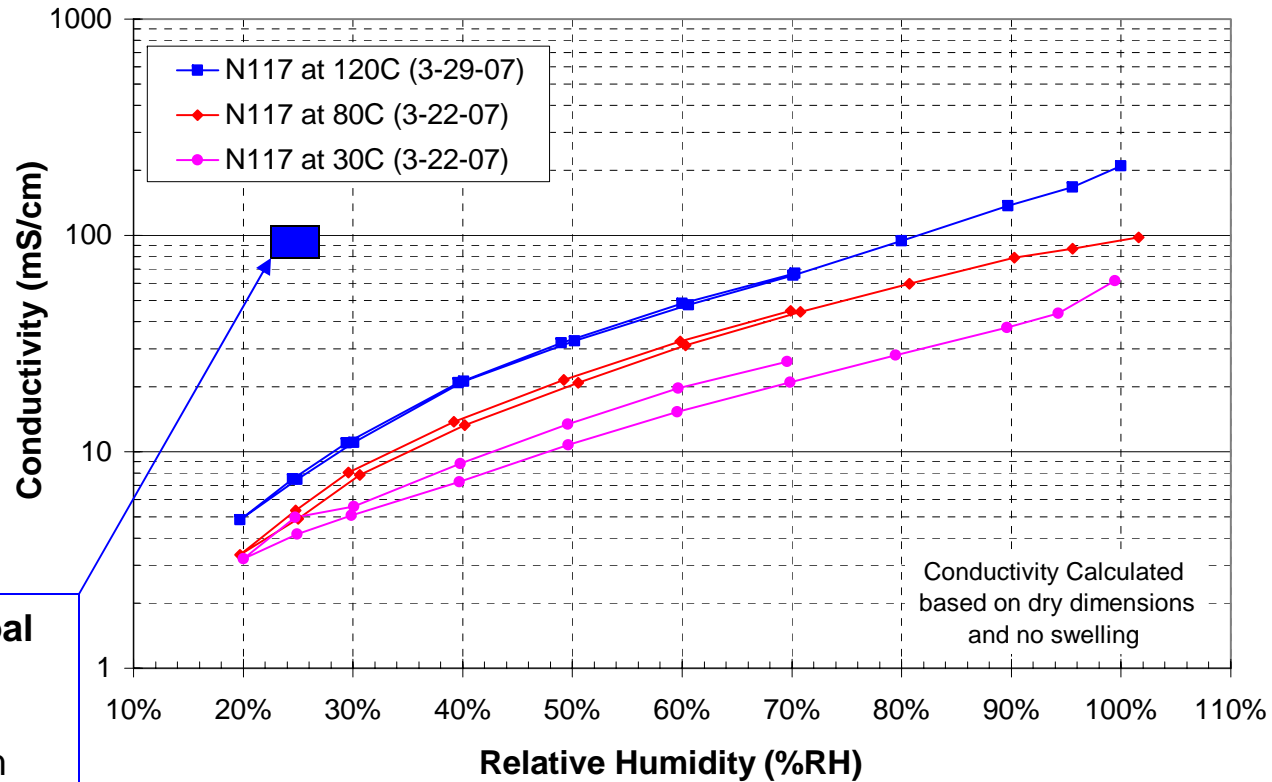

HTMWG Goal

- 120 C
- 25% RH
- 100 mS/cm



N1035 at Each Temperature

Four Electrode Conductivities of N1035

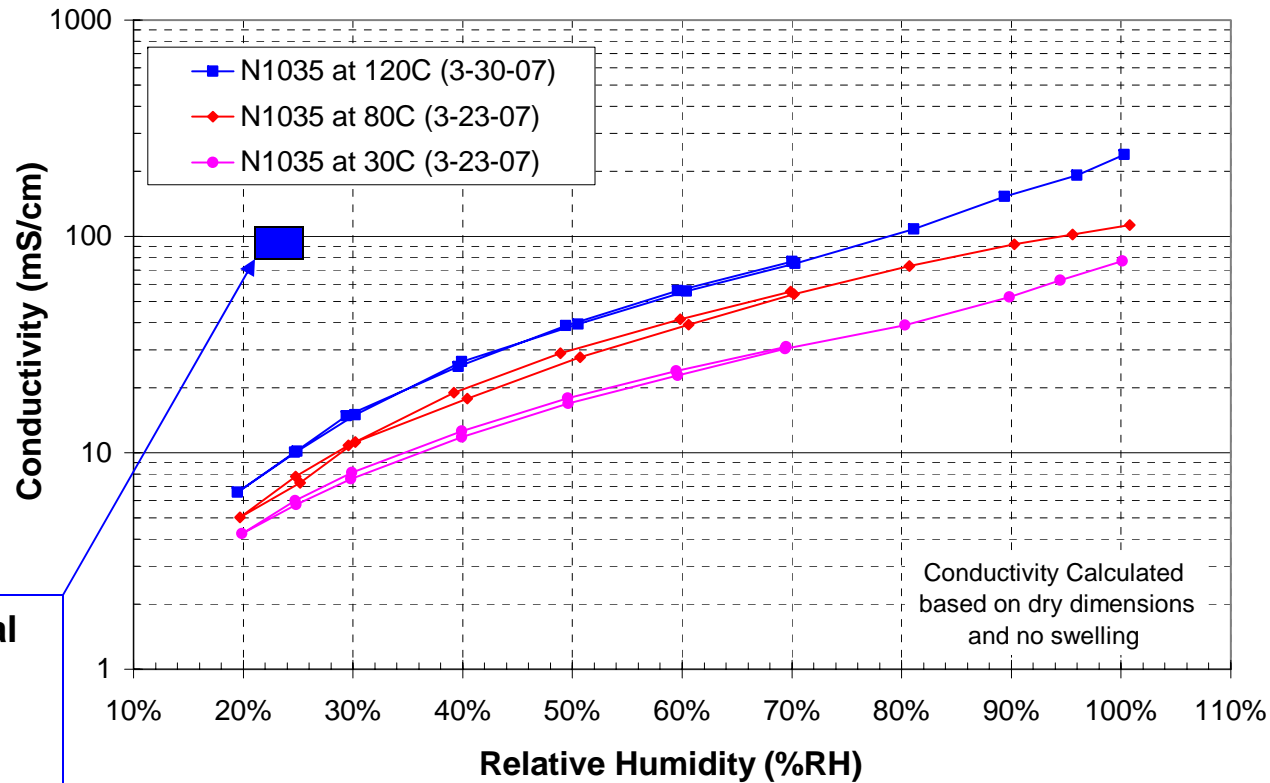

HTMWG Goal

- 120 C
- 25% RH
- 100 mS/cm



N1135 at Each Temperature

Four Electrode Conductivities of N1135

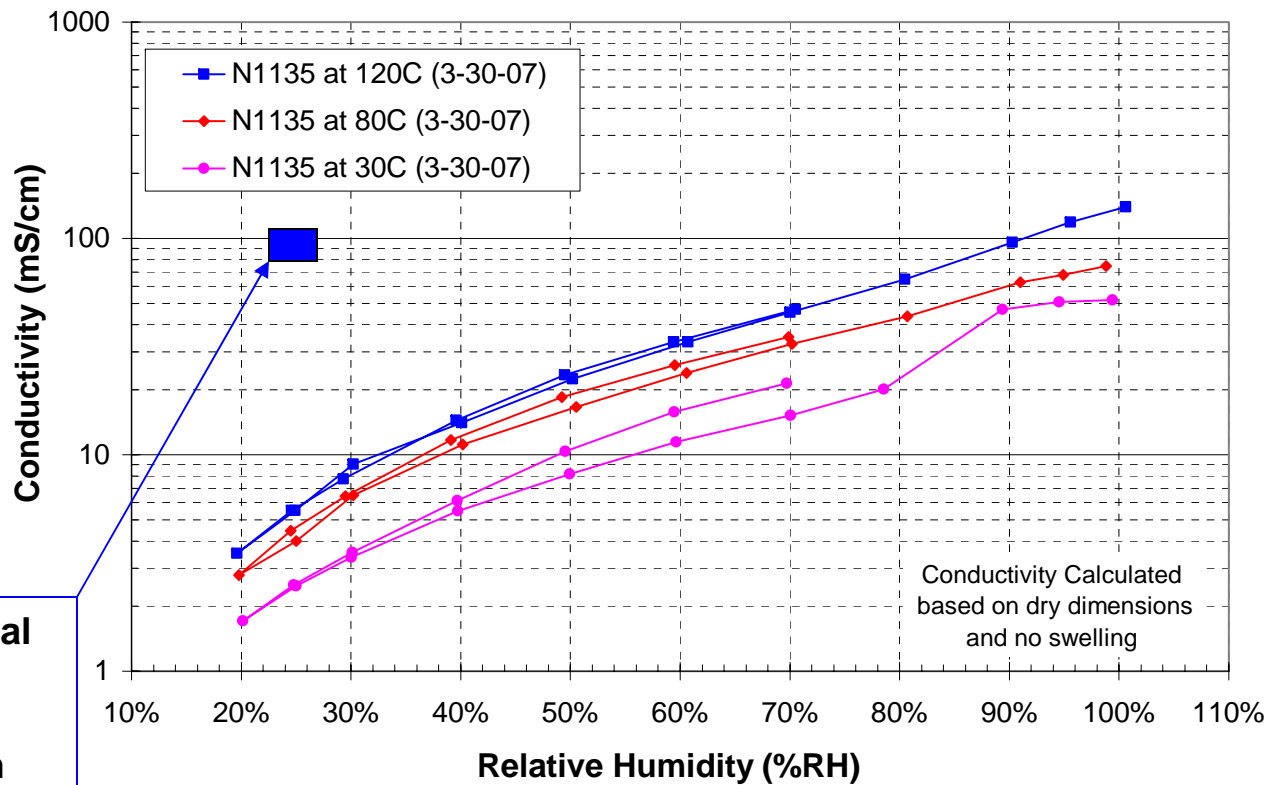

HTMWG Goal

- 120 C
- 25% RH
- 100 mS/cm



Calculation of Conductivity

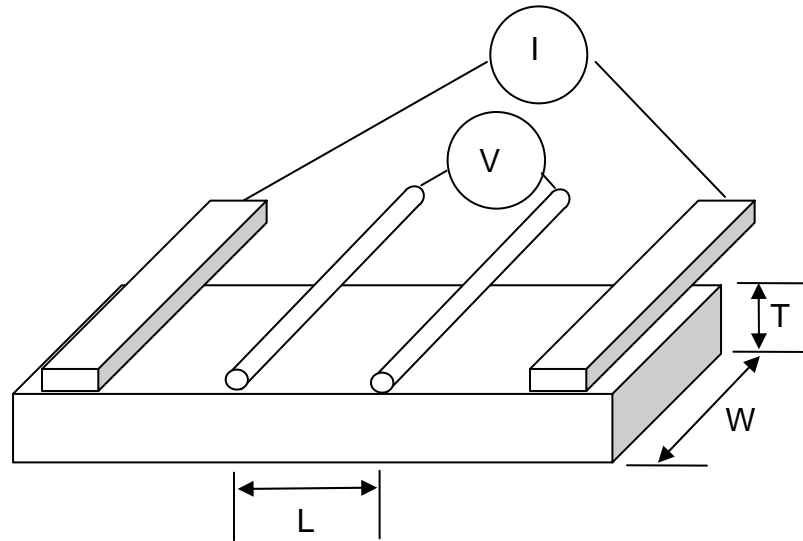

$$\sigma = \frac{L}{R * A} = \frac{L}{R * W * T}$$

$$\sigma mS = \frac{Lmm * \frac{1cm}{10mm}}{Rohms * Wmm * \frac{1cm}{10mm} * Tmicrons * \frac{1cm}{10,000microns}} * \frac{1000mS}{1S}$$